

Copyright. All information furnished within this document, electronic file or design correspondence is the property of Den Hartog industries, Inc. and shall not be used, disclosed to others or copied without the expressed written consent of Den Hartog industries, Inc.

TANK MAY BE CONVERTED FOR A BOLT-ON TOP. CUT TANK AS SHOWN. TANK CAN THEN BE USED IN APPLICATIONS REQUIRING A REMOVEABLE TOP.

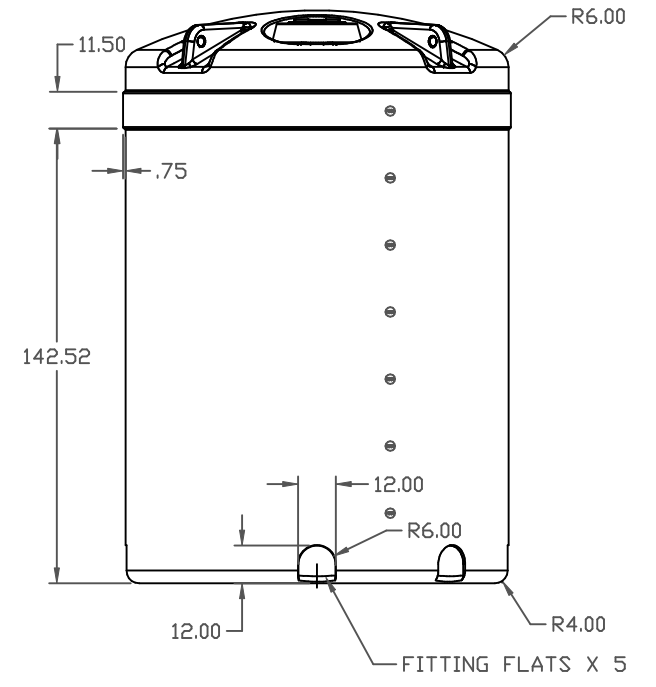

				DRAWN / DATE DHJ 12/4/06	MATERIAL
B	CORRECT VIEW PERSPECTIVE. DRAWING TEMPLATE UPDATED, ADD THICKNESS	DHJ 6/25/09	1895	APPRD. / DATE ADH 11/20/07	1.) 2 MELT POWDER 10538
A	CHANGE PART #	12/12/06			
REV	DESCRIPTION	BY / DATE	CCN		
ALL DIMENSIONS ARE IN DECIMAL INCHES TOLERANCES UNLESS OTHERWISE SPECIFIED		THIRD ANGLE PROJECTION ANSI 14.5M		SHOT WEIGHT: 1930 LBS.	NOTES: Ⓑ
POLYETHYLENE		METAL		SHIPPING WEIGHT: 1932 LBS.	1. 1.03 WALL @ FLAT
±1% @ 68° F		DECIMAL ± .125" FRACTION ± 1/4" ANGLE ± 1°		FINISH:	

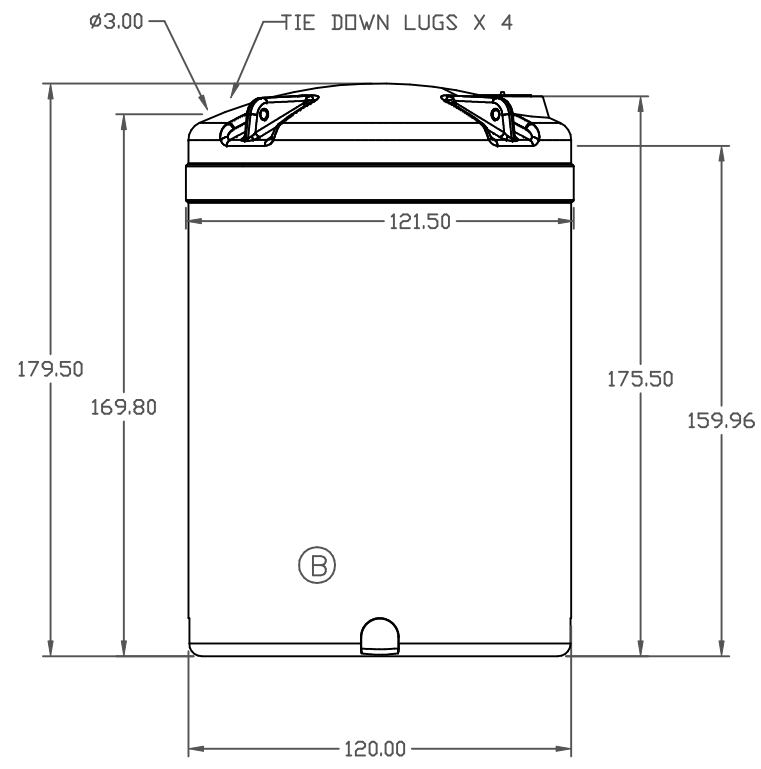
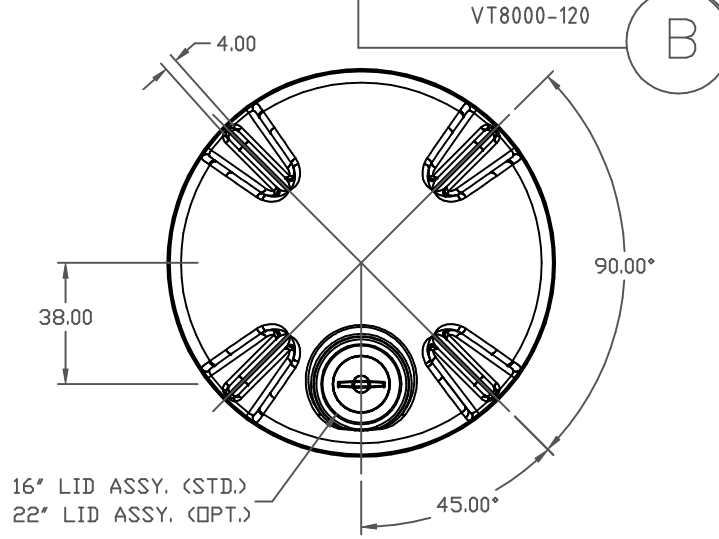
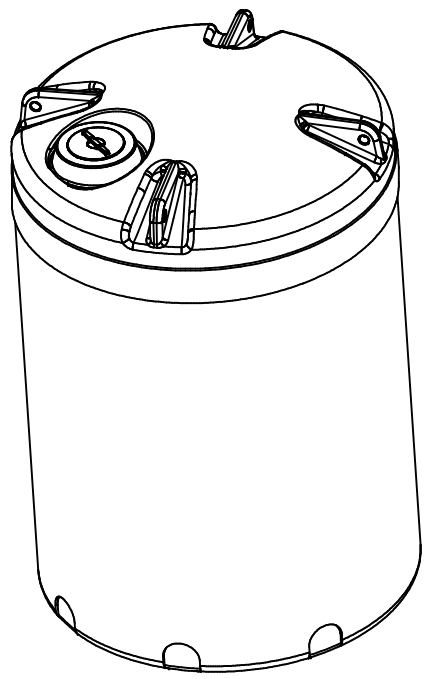
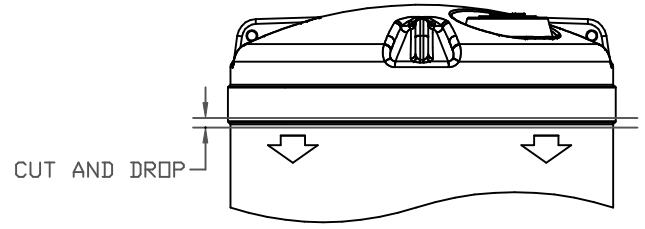

**Den Hartog**  
INDUSTRIES, INC.  
Ace Roto-Mold Injection Molding Blow Molding SawJoy  
4010 HOSPERS DRIVE S. BOX 425, HOSPERS, IOWA 51238-0421

DESCRIPTION	ACE 8000 GALLON TANK	
SCALE	N.S.	PART NO. VT8000-120