

4

3

2

1

D

D

C

C

B

B

A

A

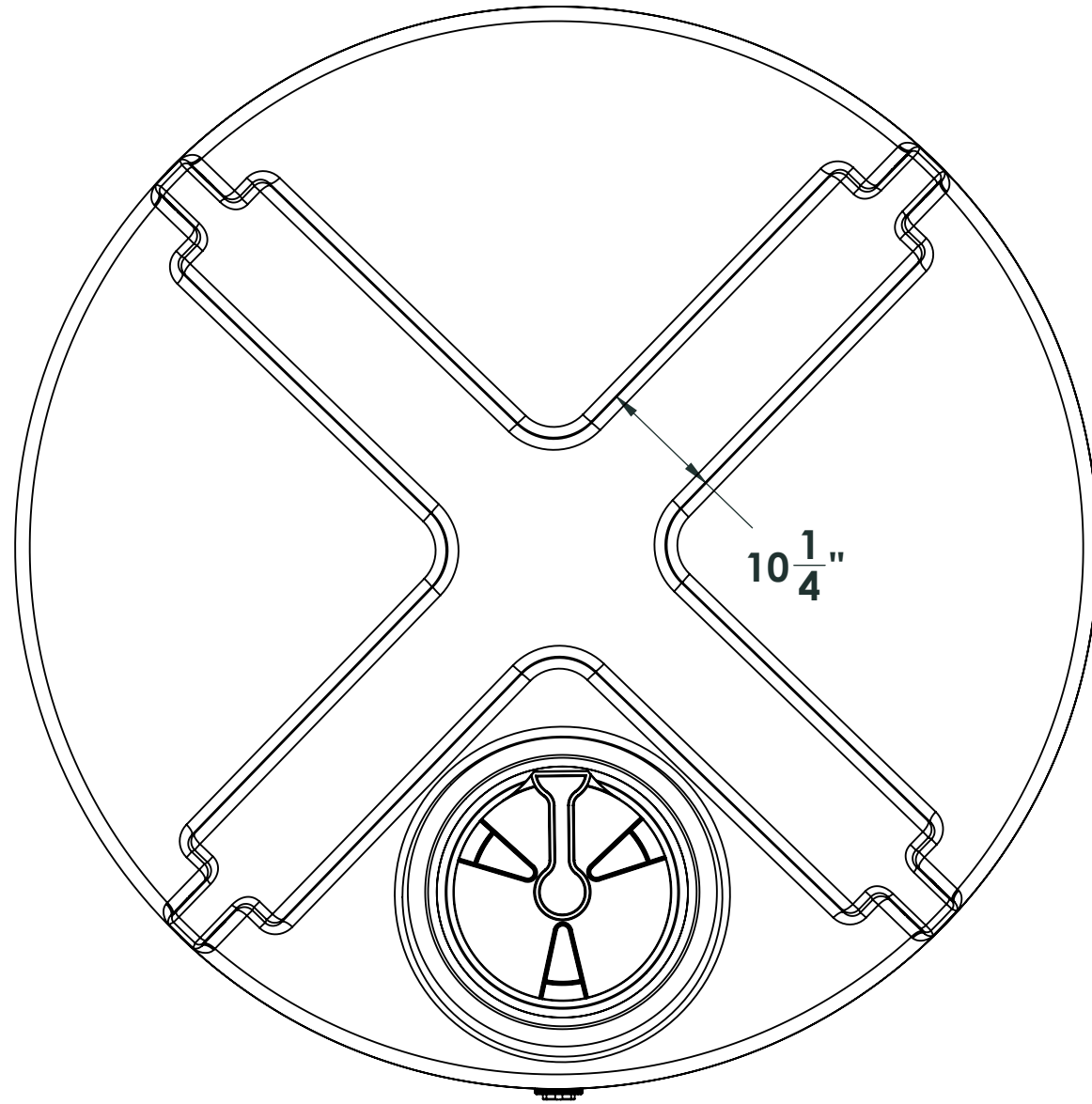

16 inch lid

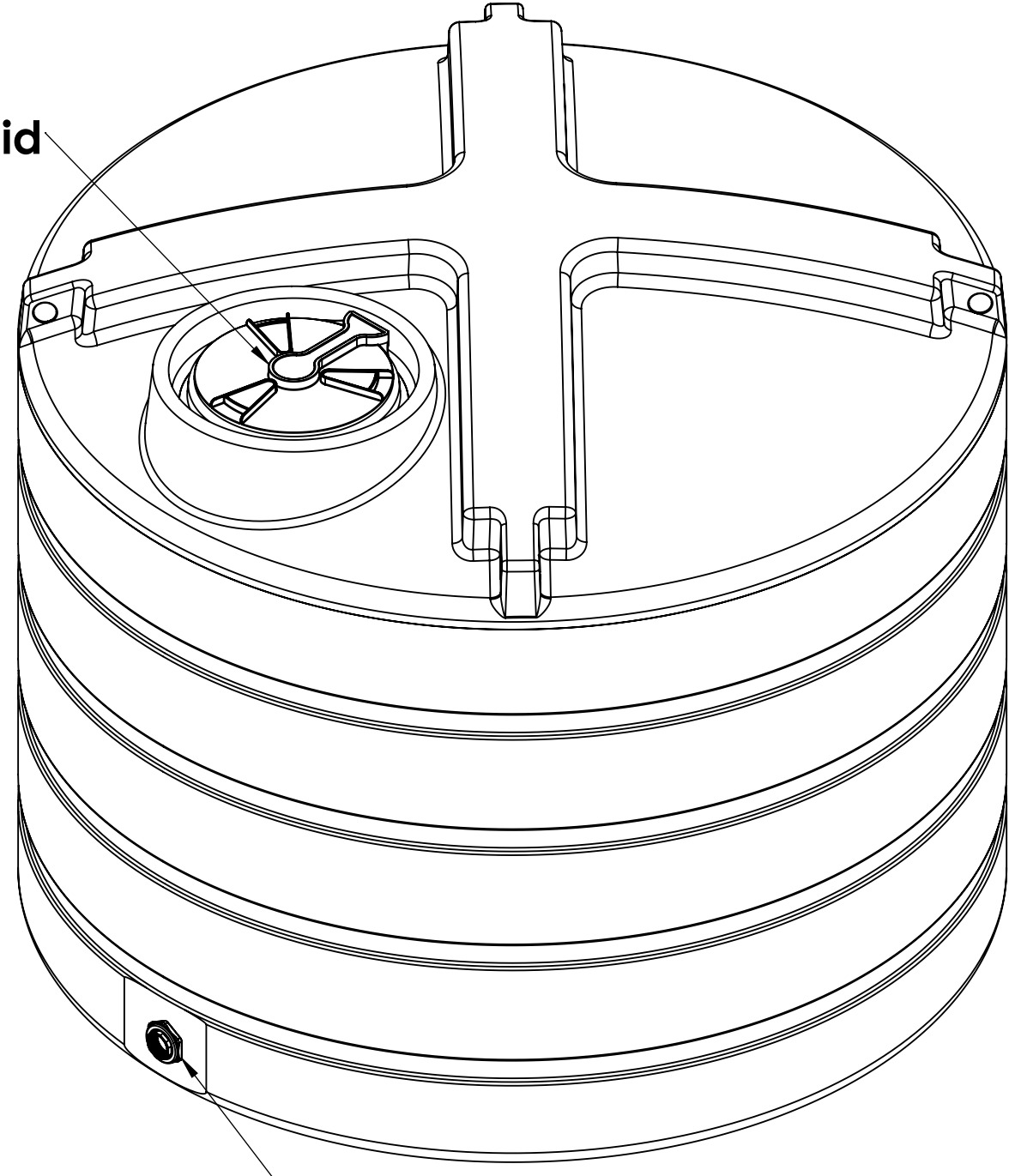

2 inch threaded fitting

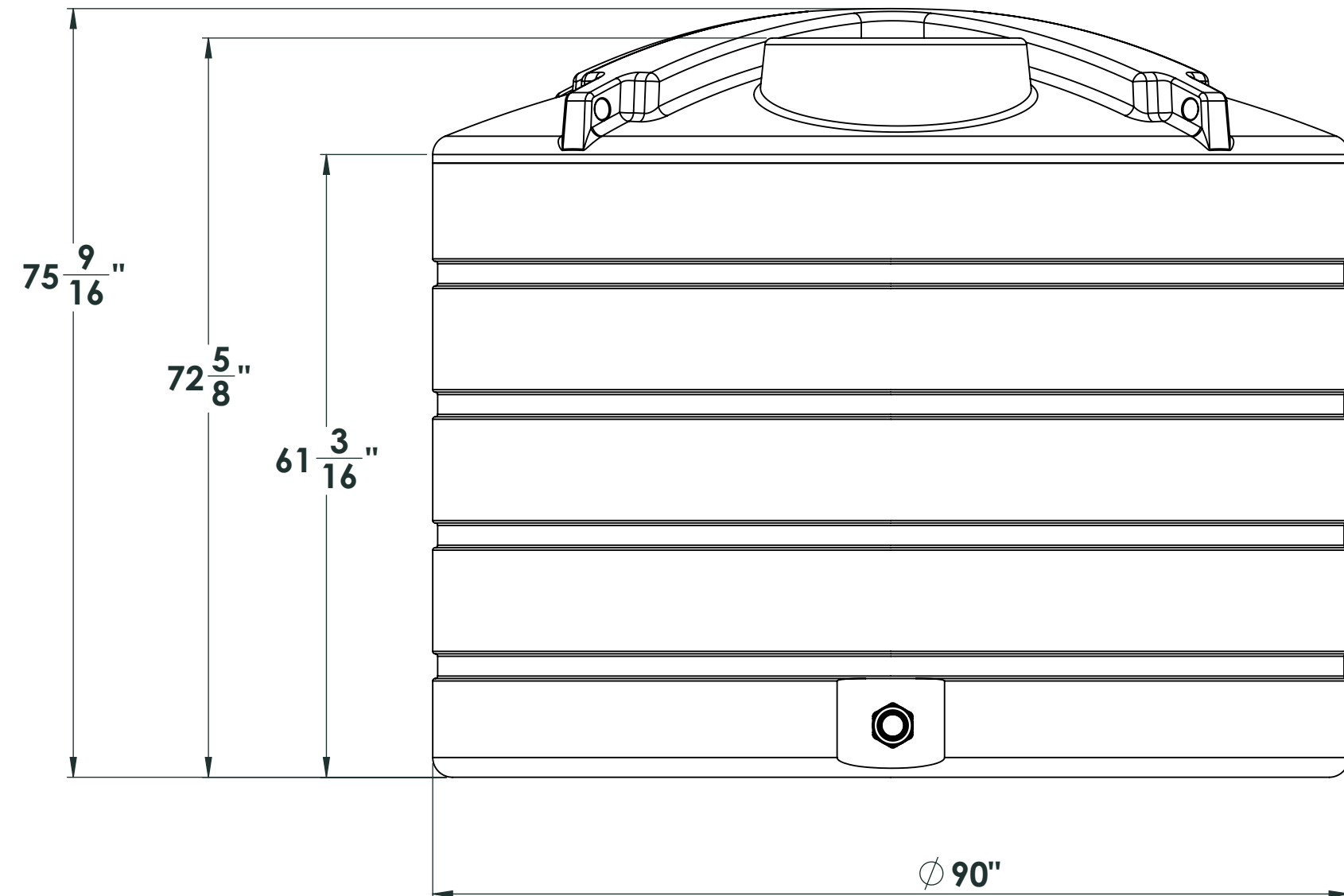

**NOTE: Allow +/- 1.5% Shrinkage**

**PROPRIETARY AND CONFIDENTIAL**  
 THE INFORMATION CONTAINED IN THIS DRAWING IS THE SOLE PROPERTY OF ENDURAPLAS LLC. ANY REPRODUCTION IN PART OR AS A WHOLE WITHOUT THE WRITTEN PERMISSION OF ENDURAPLAS LLC IS PROHIBITED.

		UNLESS OTHERWISE SPECIFIED:		NAME	DATE	ENDURAPLAS LLC	
		DIMENSIONS ARE IN INCHES		DRAWN	DNS	10/31/16	TITLE:
		TOLERANCES:		CHECKED			THV01650
		FRACTIONAL ±		ENG APPR.			SIZE DWG. NO.
		ANGULAR: MACH ± BEND ±		MFG APPR.			REV
		TWO PLACE DECIMAL ±		Q.A.			1
		THREE PLACE DECIMAL ±		COMMENTS:			SCALE: 1:50 WEIGHT:
		INTERPRET GEOMETRIC TOLERANCING PER:					SHEET 1 OF 1
		MATERIAL					
NEXT ASSY	USED ON	FINISH					
APPLICATION		DO NOT SCALE DRAWING					

4

3

2

1